

ROSE FORGROVE Flow Wrapper Merlin Mechanical



Features:

■ Flexible and Dependable

- Standard and higher speed versions available to meet varying requirements.
- Proven performance and dependability for maximum throughput.
- Ability to handle high [up to 170mm(6.70in)] and wide [300mm (11.81in)] products for optimum flexibility.
- Designed to run the broadest possible product.
- Width range from a family-sized pizza to a single pen.

■ Hygienic

- All product contact parts manufactured from stainless steel or food grade plastic.

■ Reduced Setup Times

- Quick and easy product size change for minimum downtime.
- Quick change infeed lugs or paddles.
- Low level single film reel mounting.

Barry-Wehmiller

ROSE FORGROVE Flow Wrapper Merlin Mechanical

Technical Data

All information given below is dependent upon final machine specification, feed arrangement, product type, options selected and film specification.

Electric Supply and Consumption

400V, 3-phase 50 cycles plus neutral and earth.

Up to 12 amps/phase.

Operating Pressure

5.6bar (80lbs/sqin) (minimum).

Air Consumption

Minimal and dependent upon options selected.

Environmental Conditions

Ambient temperature range: 0 to 40 degrees Celsius (104 degrees Fahrenheit).
Humidity: 0 to 80% non-condensing.
Standard sealing: IP54.

Weight

1,200kg (2,640lb)

Output

See table.

Reel Mandrel

Core: 76mm (3in).

Outside Diameter: maximum 330mm (13in).

Weight/Mandrel: 25kg (55lb).

Wrapping materials

Suitable coated cellulose films; heat-sealable lacquered materials; coated polypropylene; co-extrusion and plastics laminated to paper; film or foil. Cold films can also be used.

Standard Features

- Driven wrapper pre-feed.
- Single reel mounting.
- Pack tight/loose control.
- 2m (78.75in) infeed with single infeed pitch on a multi-pitch chain.
- Crimp release handwheel.
- Adjustment for crimp height.
- Crimp overload clutch.
- Simple, easy-to-use operator control panel.
- Individual temperature controls for top crimp, bottom crimp and long seam rollers.
- Handwheel adjustment of cut-off length and crimp dwell.
- Maintenance-free main drive gearboxes.
- Electronic speed control.
- Operator changeable fixed folding box.
- Simple, tool-free product size change.
- Wipedown finish.

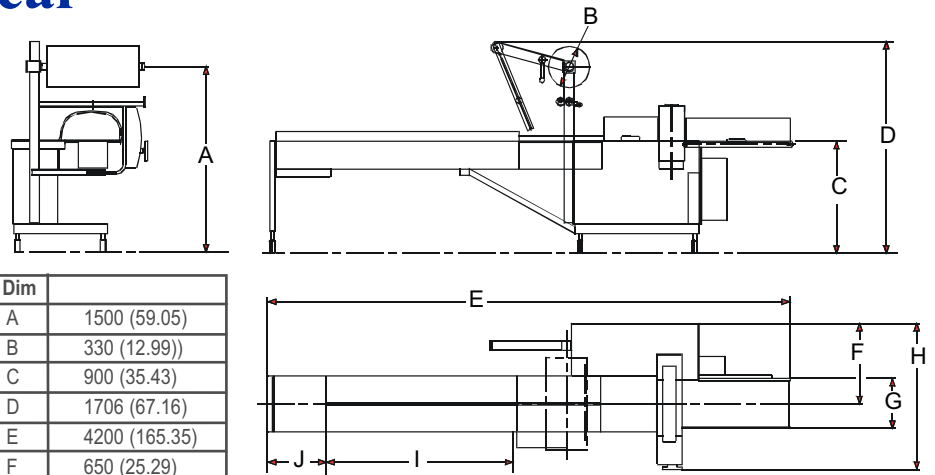

Dim	
A	1500 (59.05)
B	330 (12.99)
C	900 (35.43)
D	1706 (67.16)
E	4200 (165.35)
F	650 (25.29)
G	400 (15.74)
H	1180 (46.45)
I	1500 (59.05)
J	470 (18.50)
Dimensions in mm with equivalent inches in brackets	

- All product contact parts in stainless steel or food quality plastic.
- Designed and manufactured to comply with European machinery directives and British Standard BS5304:1988.
- Automatic opening of the heated long seam rollers (standard on high speed versions, optional on low speed versions).

Optional Features

- Stainless steel infeed and/or guards.
- Machine castors.
- Simple, adjustable folding box.
- Photo-electric cell wrapper registration.

- Reel runout sensor.
- Infeed extensions in 1.2m (47.24in) increments.
- Lipped chain guides.
- Slatted chain feed.
- Infeed overload clutch.
- Choice of crimp centres (see table below).
- Gussetting.
- Crimp carry over unit for small products.
- Euroslot crimp jaws.
- Heated cleft in long seam unit.
- 1m (39.37in) discharge extension.
- Labellers (various).
- Proprietary coding units.
- Positional stop push-button.
- Slow speed conversion (10 to 50 wraps/minute).

Parameter	Product Size Range mm (in)				
	100 (3.93)	130 (5.15)	150 (5.90)	180 (7.08)	180H (7.08)
Crimp centres	100 (3.93)	130 (5.15)	150 (5.90)	180 (7.08)	180H (7.08)
Max. product height+	50 (1.96)	75 (2.95)	95 (3.74)	120 (4.72)	170 (6.69)
Max. product length	270 (10.62)	373 (14.68)	433 (17.04)	528 (20.78)	528 (20.78)
Max. product width	150 (5.90)	300 (11.81)*	300 (11.81)	300 (11.81)	300 (11.81)#
Wrapper cut-off	70 - 315 (2.75 - 12.40)	102 - 410 (4.01 - 16.14)	117 - 470 (4.60 - 18.50)	140 - 565 (5.51 - 22.24)	140 - 565 (5.51 - 22.24)
Maximum wrapper width	450 (17.71)	450 - 750 (17.71 - 29.52)	750 (29.52)	750 (29.52)	750 (29.52)
+ If crimp carry over unit is fitted the height acceptance is reduced by 10mm (0.39). * If HS version is chosen the maximum product width is restricted to 150mm (5.90) and maximum reel gear of 450mm (17.71) # Maximum product width for products from 120mm up to 170mm (4.72 to 6.69) high is 200mm (7.87).					
Crimp centres		Without crimp carry over unit		With crimp carry over unit	
100mm (3.93) - narrow		20 to 150 wraps/minute		Not available.	
130mm (5.11) - narrow		20 to 150 wraps/minute		Not available.	
130mm (5.11) - wide		20 to 100 wraps/minute		20 to 70 wraps/minute	
150mm (5.90) - wide		20 to 100 wraps/minute		20 to 70 wraps/minute	
180/180mm H (7.08) - wide		20 to 70 wraps/minute		20 to 70 wraps/minute	

HayssenSandiacre

USA - 225 Spartangreen Boulevard • Duncan, SC 29334 USA • 864/486-4000

UNITED KINGDOM - 16 Roman Way • Thetford, Norfolk IP24 1XB United Kingdom • + 44 (0) 1842 754171

UNITED KINGDOM - 101 Lilac Grove • Beeston, Nottingham, NG9 1PF • United Kingdom • +44 (0) 115 967 8787

MEXICO - Castorena 324-118 • Cuajimalpa • 05000 México, D.F • +(52-55)5813-7770

www.hayssensandiacre.com • sales@hayssensandiacre.com