

ROSE FORGROVE ATHENA Flow Wrapper



Proven, Dependable Performance

Rose Forgrove's Athena Flowpak distinguishes itself through innovative engineering that focuses on delivering exceptional performance and functionality without compromising durability and simplicity. The Athena's foundation begins with high-quality components and materials that create a modular, open design for thorough sanitation and quick no-tool changeovers. Its servo technology platform ensures years of efficient, cost effective operation. The Rose Forgrove Athena: Extraordinary performance and a tremendous value for your packaging application.

■ Flexible and Reliable

- Extensive machine range - narrow and wide models available to meet varying package sizes and speeds
- Single and twin jaw configurations
- Multi-axis servo drive technology
- Vast range of in-feed systems to meet your specific application

■ Sanitation

- Compact design with heavy gauge steel construction with stainless steel product contact points. Stainless Steel wash-down construction options available
- Accessible, open construction for thorough cleansing

■ Efficiency

- Twin reel film mounting optional with automatic film splicing
- Quick and simplistic product size changeovers
- Straight-forward and intuitive operator's set-up features
- 'No product-no bag' feature keeps film waste to a minimum
- "Misplaced product detection" eliminates product damage and avoids jams

■ Control Platform

- Allen Bradley or B&R based control platforms available
- Icon based operator interface with extensive, real time diagnostics
- Storage of 100 product recipes
- Integral temperature controls with parameter adjustments on the fly

Barry-Wehmiller

ROSE FORGROVE ATHENA Flow Wrapper

Standard Features

- Robust, solid design (3,750lbs) provides years of dependable service
- 2M (78.75in) infeed with multi-pitch chain
- On-screen statistics and diagnostics assist in speed and simplify the flow wrapping process
- Multi-axis servo drives for outstanding versatility
- ‘No-product/no-bag’ feature
- Driven wrapper pre-feed
- Multiple crimp height selections
- Individual temperature controls for top/bottom crimpers and long seam rollers
- Simple, tool-free product size changeovers

Optional Features

- Range of fully- and semi-automatic product feeding systems
- Stainless steel washdown construction
- Twin reel mounting with automatic film splicing
- Various printing and labeling units
- Automatic pack reject station
- Infeed extensions
- Water-cooled long seal deadplates (chiller available)
- Gas flushing system (MAP)
- Twin jaw configuration
- Pack gusseting device

Technical Data

All information given below is dependent upon final machine specification, feed arrangement, product type, options selected and film specification.

Power Requirements:

480V, 3-phase 50/60 cycles

Up to 40 amps/phase.

Air Requirements

5.6 bar (80lbs/sqin) (minimum).

Air Consumption

Minimal but dependent upon options selected.

Package Range:

Minimum Width: 0.80" (20mm)
Length: 0.40" (10mm)
Height: 0.25" (6mm)

Maximum Width: 15.75" (450mm)
Length: 21.25" (540mm)
Height: 6.70" (150mm)

Production Rate

Up to 400 wraps/minute -depending on product and wrapper

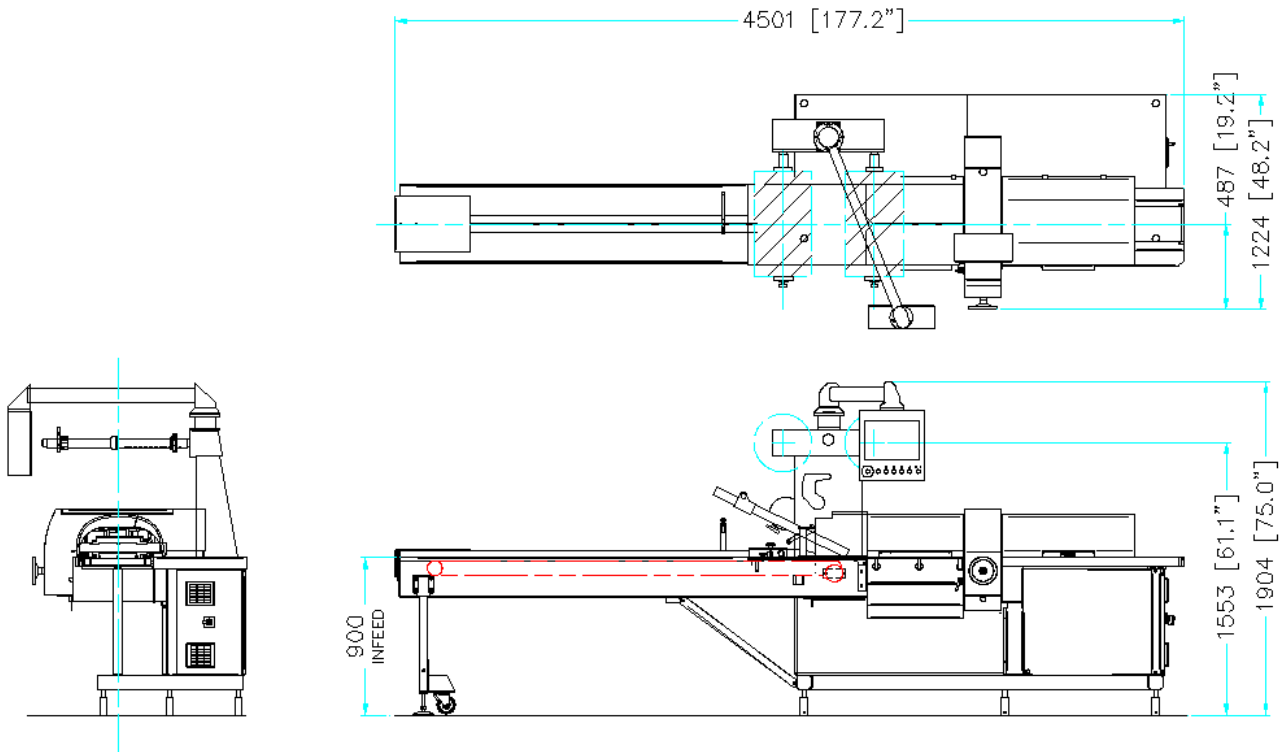

HayssenSandiacre

USA - 225 Spartangreen Boulevard • Duncan, SC 29334 USA • 864/486-4000

UNITED KINGDOM - 16 Roman Way • Thetford, Norfolk IP24 1XB United Kingdom • + 44 (0) 1842 754171

UNITED KINGDOM - 101 Lilac Grove • Beeston, Nottingham, NG9 1PF • United Kingdom • +44 (0) 115 967 8787

MEXICO - Castorena 324-118 • Cuajimalpa • 05000 México, D.F • +(52-55)5813-7770

www.hayssensandiacre.com • sales@hayssensandiacre.com