

# HayssenSandiacre

## Ultima SV



### Key Features

- High Speed Intermittent Motion VFFS Technology
- User-friendly Allen-Bradley PV1000 Plus monochrome touch screen operator interface
- Off-the-shelf Allen-Bradley control system SLC5/04 PLC
- Heavy-duty jaw assembly houses a cushion for shock and noise abatement
- More dwell time for better looking seals and increased packaging speeds.
- Servo driven self centering pull belts
- Patented Measure, Form, Pull film advance concept, stepper motor driven

# Barry-Wehmiller

**ACCRAPLY**  
Barry-Wehmiller  
International Resources

**pneumatic SCALE**  
**ANGELUS**  
HayssenSandiacre

**PC**  
Thiele Technologies  
MarquipWardUnited

DESIGN **DG** GROUP  
FleetwoodGoldcoWyard

# Ultima SV

The Ultima SV has a long-standing reputation as a solid, durable member of the Ultima family of VFFS machines.

The Ultima SV's servo-driven system features off-the-shelf Allen-Bradley Panelview 1000 operator interface with Allen-Bradley SLC 5/04 programmable controller. Sealing systems for laminate and polyethylene packaging materials can be customized to meet your application requirements.

### Production Rate

Up to 120 bags per minute

### Package Range

Minimum Width: 2-1/8" (54mm)

Minimum Length: 3" (76mm)

Maximum Width: 8" to 18" (203 to 457mm) depending on frame size

Maximum Length: 8" to 28" (203 to 711mm) depending on frame size

### Power Requirements

230/460 vac, single phase, 50/60 hz, 30 amp service

### Air Requirements

2.5 scfm @ 65 psi

Let us customize an Ultima SV to meet your specific requirements, whether it is a specific bag style or a production need the Ultima SV is a proven performer.

A few of the many available options include stainless steel construction, integrated zipper applicator, various hole punches, tear notches, code daters, gas flushing, static eliminators and tucking devices. We have extensive experience in integrating a wide variety of feed systems including scales, augers, volumetrics and pumps for a wide variety of applications.

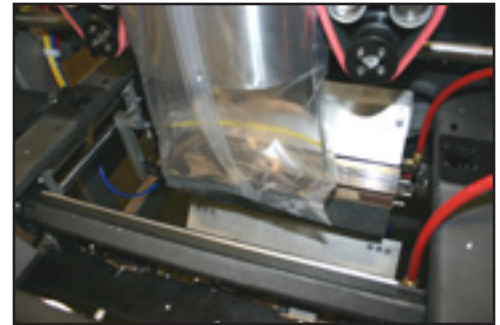

*Consistent High Quality Seals*

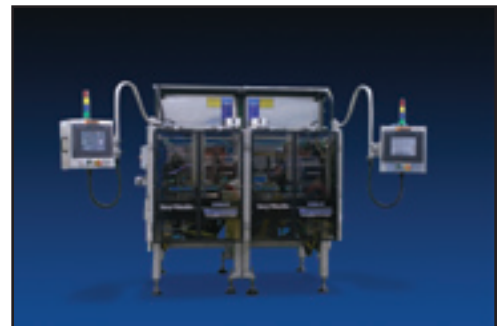

*Twin SV System*

#### Latin America

Castorena 324-118, Cuajimalpa, 05000  
Mexico, D.F.  
Ph. +52(55)58137770  
salesla@hayssensandiacre.com

#### Europe

101 Lilac Grove, Beeston, Nottingham  
NG9 1PF United Kingdom  
Ph. +44 (0) 115 967 8787  
sales@hayssensandiacre.co.uk

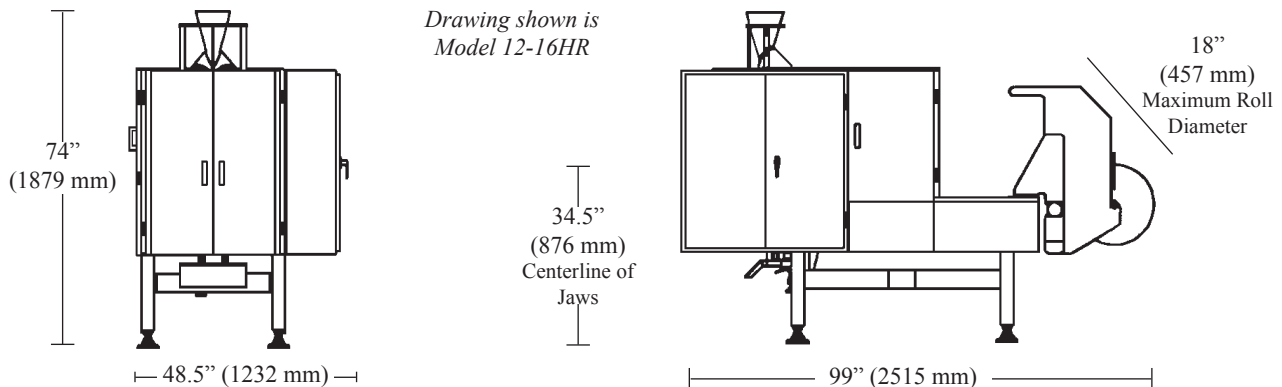

## HayssenSandiacre

225 Spartangreen Boulevard, Duncan, SC 29334 • (864) 486-4000

sales@hayssensandiacre.com • www.hayssensandiacre.com