

HayssenSandiacre

Continuous Motion ULTIMAX CM



Key Features

- The ultimate in sanitary design with true stainless steel washdown, resistance to caustic cleaning solutions, rounded frame members and sloped surfaces
- Allen-Bradley ControlLogix platform with off-the-shelf components, on-screen manuals and quick response screens
- Continuous motion jaw actuation
- Quick changeover, no tools
- Sealed electrical cabinet integrated in frame
- Rapid tracking response

Barry-Wehmler

Continuous Motion Ultimax CM

The ULTIMAX CM is the first machine of its kind, offering true stainless steel wash down capabilities. All components, both internal and external, have been carefully chosen to withstand the rigors of daily wash down using caustic chemicals. All metal materials are stainless steel, all electrical components are sealed, and all servo motors are stainless steel.

The continuous motion jaw makes an easier landing for the product and more cooling time for poly films. The ULTIMAX CM is programmed to maintain sealing time regardless of bagging rate.

The advanced user interface features Allen-Bradley 12" Versa View HMI, multiple security levels, multi-language operator interface. The interface is user customizable and provides production data locally or remotely via ethernet.

Production Rate

Up to 130 bags per minute

Package Range

Minimum Width: 2" (50.8mm)

Minimum Length: 2" (50.8mm)

Maximum Width: 10" to 15" (254 to 381mm) depending on frame size

Maximum Length: Unlimited (practical limits are determined by outfeed and machine installed height)

Power Requirements

230 vac, single phase, 50/60 hz, 30 amp service

Air Requirements

4.2 scfm @ 65 psi @ 60bpm (laminar)

Let us customize an ULTIMAX CM to meet your specific requirements, whether you are facing a harsh production environment or require a certain package style, the ULTIMAX CM is a durable, proven performer.

We have extensive experience in integrating a wide variety of feed systems including scales, augers, volumetrics and pumps for a wide variety of applications.



Advanced user interface simplifies programming



All components, both internal and external, have been chosen to withstand daily wash down

Latin America

Castorena 324-118, Cuajimalpa, 05000
Mexico, D.F.
Ph. +52(55)58137770
salesla@hayssensandiacre.com

Europe

101 Lilac Grove, Beeston, Nottingham
NG9 1PF United Kingdom
Ph. +44 (0) 115 967 8787
sales@hayssensandiacre.co.uk

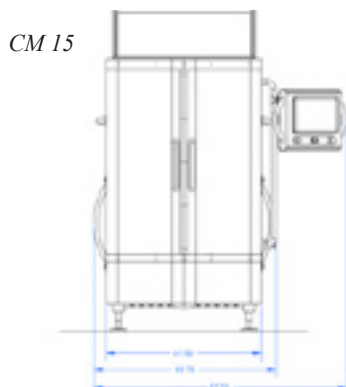

*Ultimax Dimensions
CM 10, CM 13 and CM 15*

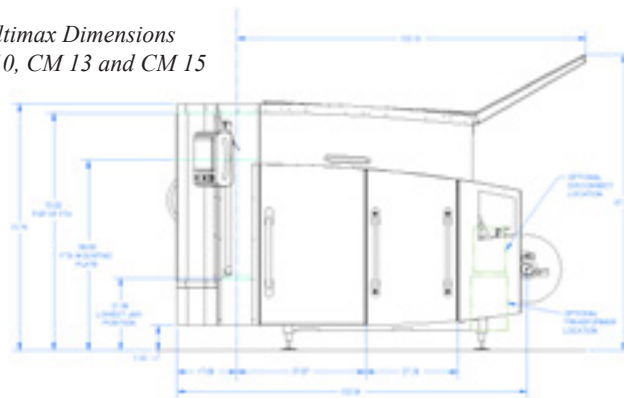

HayssenSandiacre

225 Spartangreen Boulevard, Duncan, SC 29334 • (864) 486-4000

sales@hayssensandiacre.com • www.hayssensandiacre.com